

GENEVA MECHANISMS

**90° & 72°
MOTION**

FOR INTERMITTENT MOTION 1/4" SHAFT SIZE

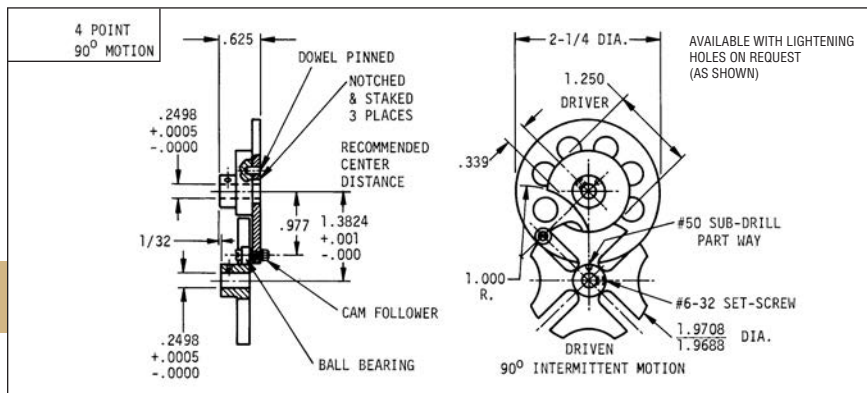

May be driven in either direction

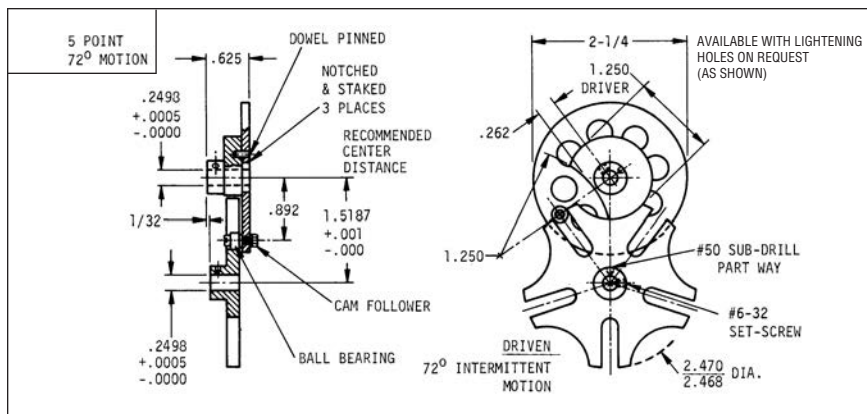

Material: Stainless Steel.

1/8" and 3/16" shaft units available on request

ORDER BY CATALOG NUMBER

| Catalog Number | Number of Points | Intermittent Motion |
|----------------|------------------|---------------------------|
| EAS-A1-1 | 4 | *360° Driver = 90° Driven |
| EAS-A1-2 | 5 | 360° Driver = 72° Driven |

*For modified driver with 2 rollers at 180° please add MD to the catalog number. There is an additional charge for this service. Cam follower screws are supplied in 17-4 heat treated condition.